

Avalon

BATHROOMS

Redefining your space

Bathroom Furniture Installation & After Care Guide

including

GUARANTEE REGISTRATION FORM

Please read this guide carefully before commencing installation. When the installation is complete, the consumer should be advised to register their product for guarantee. Information on how to do this can be found at the end of this guide.



ISSUE 01-03-25

INDEX

Page 1-6	General installation notes and guidelines.
Page 7 -12	Wall bracket installation and adjustment.
Page 13 -15	Hinge and drawer adjustment.
Page 16	Chiaro mirror.
Page 17	Semi recess basin installation.
Page 18	Solid Surface Worktop Installation.
Page 19 – 21	Toilet seat installation & Help.
Page 22	General notes.
Page 23 – 24	Care and maintenance guidelines.
Page 25	Guarantee information.
Page 26	Guarantee registration.

Do not forget to register your product.

Fill out and return your guarantee registration form which can be found at the back of this booklet.

IMPORTANT INSTALLATION NOTES

Avalon Bathroom Furniture **MUST** be installed by an appropriately qualified professional. It is the installer's responsibility to ensure the product supplied is installed to all current regulations.

In the unlikely event that your product is damaged or faulty in any way, this must be notified on delivery or within **48 hours** of delivery and must not under any circumstances be installed.

Time must be allowed between delivery and installation for checking items and the delivery of subsequent replacements. In all cases, to ensure replacement parts are dispatched efficiently, and to improve our systems and service to you, we will require photographic images of faulty or damaged goods.

All products must be inspected carefully before installation. Check you have everything you have ordered, and it will fit to your design.

Always unpack units carefully from the packaging and check the contents before discarding the packaging. Usually, small items such as handles, are stored for transportation inside the units.

Never carry units by their rails as this may cause them to break. Take care when lifting heavy products, always follow health and safety guidelines.

When cutting the worktop section of a **Largo Orlo/Meno basin**, ensure both the basin and worktop section, are fully supported whilst cutting. During cutting wear appropriate clothing/dust protection including a dust mask offering protection grade FFP3.

When using knives or blades to remove packaging be careful not to damage the product. Avalon bathroom furniture is designed for use within domestic installations that are adequately ventilated. Bathroom extractor fans must be installed to prevent heavy condensation. Not suitable for installation in wet-rooms.

We recommend that all doors, drawers, fascia panels and glass shelves are removed and stored safely during the installation process. This will ease installation and prevent damages.

All units must be individually fixed to the wall via the adjustable hanger brackets. If units are screwed together, every unit must still be individually anchored to the wall, using the hanger brackets and suitable wall fixings.

When fitting wall hanging units a firm fixing must be achieved. It is the responsibility of the installer to make sure that any fixings used are suitable for the individual installation in question. If a firm fixing is not achievable with any unit, then the additional use of strapping or adjustable support legs (in the case of base units) is recommended.

Ensure a good quality silicone sealant is used to prevent water ingress as this will damage the product and void any guarantees. **Any cut edges MUST** be resealed. Particular attention should be given to areas around the basins, showers and baths.

Installation of electrical equipment **MUST** be made in accordance with the current IEE wiring regulations and relevant building regulations. We recommend that all electrical bathroom products should only be fitted by a suitably qualified electrician.

Always observe good safety working practices. If you are unsure or you need extra advice, please call our customer services on **01706 876000**.

INSTALLATION GUIDE ECO BATHROOMS

Note: We recommend you remove the doors, drawers, panels and glass shelves before you commence the installation. Ensure these items are stored away safely.

All Avalon bathroom furniture is supplied rigid to reducing fitting time. Lay the unpacked unit on its back on a clean flat surface. At this stage do not remove any of the clear protective film that may be on the units or doors (Gloss, Metro, Senza and Daresbury ranges).

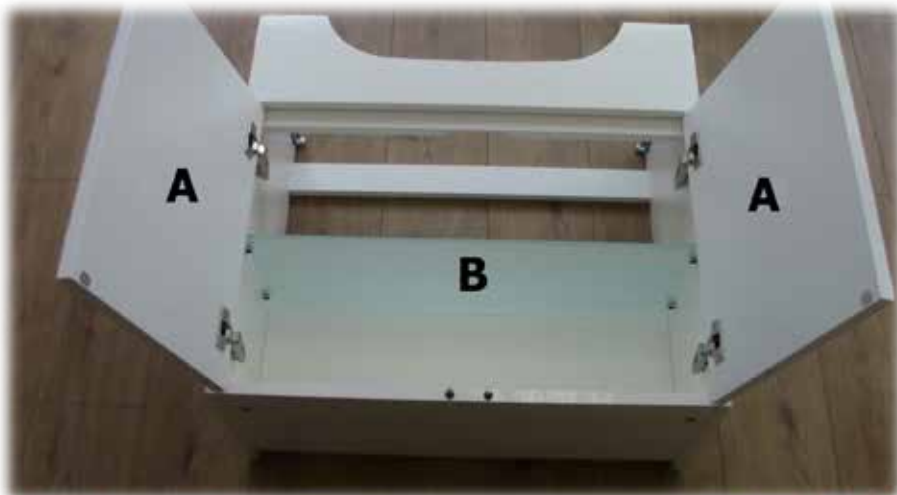

To remove the doors, unclip the hinges from the back plate.

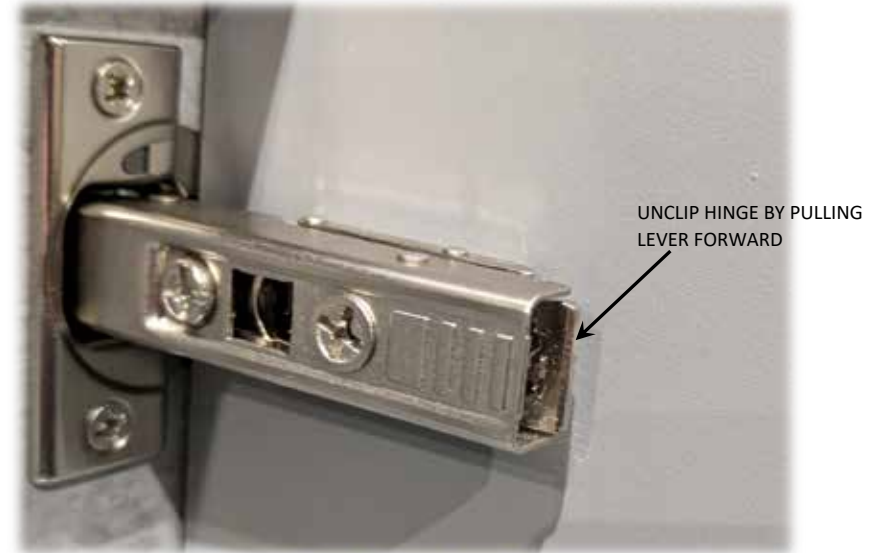

Remove any glass shelves by loosening the grub screw on the underside of the shelf peg. When refitting do not over tighten as this may break the glass.



Basin/WC fascia's and removable backs are secured using fixing clips. We use two types of clips, see images below.

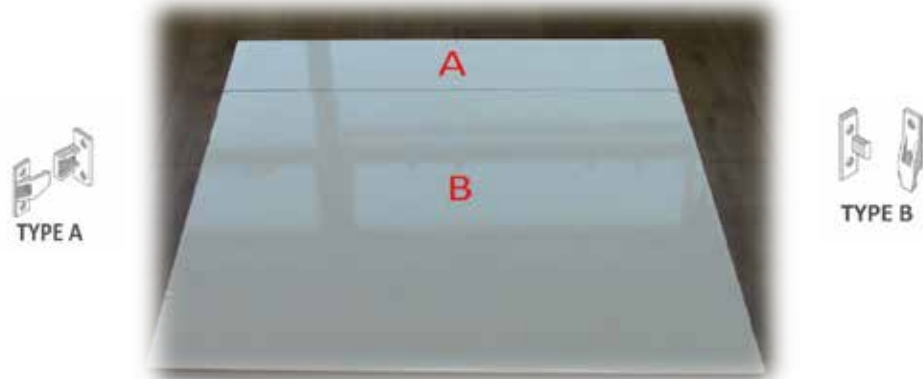

To remove the top fascia's pull forward from the unit to separate the clips (Type A). To refit push back into place.



To remove the bottom panel of a WC unit or a removable back, push the panel upward to separate the clips (Type B). To refit, push panel down over clip.



FITTING ADJUSTABLE BLACK PLASTIC LEGS

If using adjustable legs, lay the units on a clean flat surface, so as not to scratch or damage the unit.



Insert the black boss socket of the legs into the base of the unit. Ensure that the flat tab sides of the leg socket run parallel to the side of the unit. This gives extra support to the unit gable (Note if using a plinth return the plinth will need to be notched around these to enable the plinth to sit flush). Secure the boss in position knocking in the retaining pin A with a soft mallet.



Push the legs into the boss socket (they may need a tap with a soft mallet to achieve a secure fit).



Adjust the legs to allow a space of approximately 200mm between the underside of the unit and the floor.

Once all necessary pipe work is completed, position the unit on its legs and against the wall. Ensure that the unit sits level in both directions. Make any notches as necessary for pipework that runs along the back of the furniture units. Re-seal any bare mfc with silicon sealant.

Note: Always carry the unit into position - do not drag the units across the floor - this will damage the unit where the legs are fastened.

Units are only pre-drilled for legs if legs are specified on the order.

WALL HANGER (TYPE) MATRIX

Fitted Furniture					
Unit Type	Height	Depth	Widths	Back Type	Type
Slimline Base Cabinet Single Door	638mm	220mm	150mm, 200mm, 250mm, 300mm, 350mm, 400mm	Solid	B
Slimline Base Cabinet Double Door	638mm	220mm	300mm, 400mm, 500mm, 600mm, 700mm	Solid	B
Slimline Toilet Roll Cabinet	638mm	220mm	200mm, 250mm	Solid	B
Slimline Basin Cabinet	638mm	220mm	500mm, 600mm, 700mm	Removable	A
Slimline WC Cabinet	838mm	220mm	400mm, 500mm, 600mm, 700mm	No Back	A
Slimline Tower Cabinet	1750mm	220mm	300mm	Solid	B
Slimline Midi Storage Unit	1112mm	220mm	600mm	Solid	B
Standard Base Cabinet Single Door	638mm	340mm	150mm, 200mm, 250mm, 300mm, 350mm, 400mm	Solid	B
Standard Base Cabinet Double Door	638mm	340mm	300mm, 400mm, 500mm, 600mm, 700mm	Solid	B
Standard Toilet Roll Cabinet	638mm	340mm	200mm, 250mm (With Bin)	Solid	B
Standard Basin Cabinet	638mm	340mm	500mm, 600mm, 700mm, 1200mm	Removable	A
Standard Corner Cabinet	638mm	340mm	600mm (With 297mm Door - Allow 35mm Void)	Solid	B
Standard Two Drawer Basin Cabinet	638mm	340mm	500mm, 600mm	No Back	A
Standard Three Drawer Cabinet	638mm	340mm	300mm, 500mm, 600mm	No Back	A
Standard WC Cabinet	838mm	340mm	400mm, 500mm, 600mm, 700mm	No Back	A
Standard Tower Cabinet	1750mm	340mm	300mm	Solid	B
Standard Midi Storage Unit	1112mm	340mm	600mm	Solid	B
Standard Wall Cabinet Single Door	638mm	220mm	150mm, 200mm, 250mm, 300mm, 350mm, 400mm	Solid	B
Standard Wall Cabinet Double Door	638mm	220mm	300mm, 400mm, 500mm, 600mm, 700mm	Solid	B
Cloakroom Furniture					
Unit Type	Height	Depth	Widths	Back Type	Type
2 Door Basin Cabinet Floor Mounted	838mm	385mm	500mm, 600mm	Removable	A
2 Door Basin Cabinet Wall Hung	638mm	385mm	500mm, 600mm	Removable	A
Mini Cloakroom Cabinet Floor Mounted	838mm	240mm	450mm	No Back	A
Mini Cloakroom Cabinet Wall Hung	573mm	240mm	450mm	No Back	A
Slimline WC Cabinet With Top	856mm	220mm	500mm, 600mm	No Back	A
Standard WC Cabinet With Top	856mm	340mm	500mm, 600mm	No Back	A
Combi WC Cabinet	838mm	340mm	500mm	No Back	A
Std 2 Door Basin Cabinet Floor Mounted	838mm	340mm	600mm	Removable	A
Std 2 Drawer Basin Cab Floor Mounted	838mm	340mm	600mm	No Back	A
Standard Tower Cabinet	1636mm	340mm	300mm	Solid	B
Standard Wall Cabinet Double Door	638mm	220mm	500mm, 600mm	Solid	B
Modular Furniture					
Unit Type	Height	Depth	Widths	Back Type	Type
1 Drawer Basin Cabinet	286mm	450mm	600mm, 800mm, 1000mm	No Back	C
2 Drawer Basin Cabinet	574mm	450mm	600mm, 800mm, 1000mm	No Back	C
Slimline WC Cabinet With Top	856mm	220mm	500mm, 600mm	No Back	A
Standard WC Cabinet With Top	856mm	340mm	500mm, 600mm	No Back	A
Slimline Tower Cabinet	1750mm	220mm	300mm	Solid	B
Standard Tower Cabinet	1750mm	340mm	300mm	Solid	B
2 Drawer Basin Cabinet (Bello)	600mm	450mm	600mm, 800mm, 1000mm	No Back	C
Standard WC Cabinet With Top (Bello)	886mm	340mm	600mm	No Back	A
Standard Tower Cabinet (Bello)	1464mm	340mm	300mm	Solid	B
1 Drawer Basin Cabinet (Apri)	574mm	450mm	600mm, 1000mm	No Back	C
Standard WC Cabinet With Top (Apri)	856mm	340mm	640mm	No Back	A
Standard Tower Cabinet (Apri)	1750mm	340mm	300mm	Solid	B

WALL HANGER BRACKET POSITION

Bracket type "A"

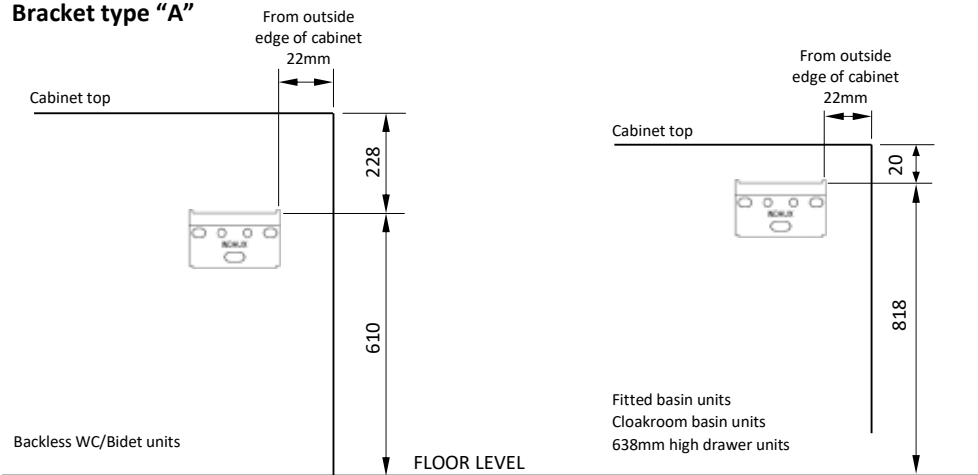

Bracket type "B"

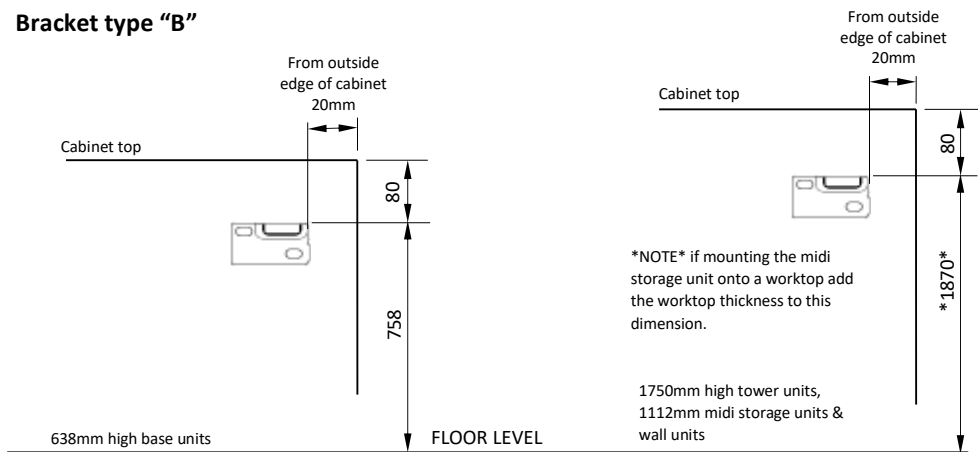

Bracket type "C"

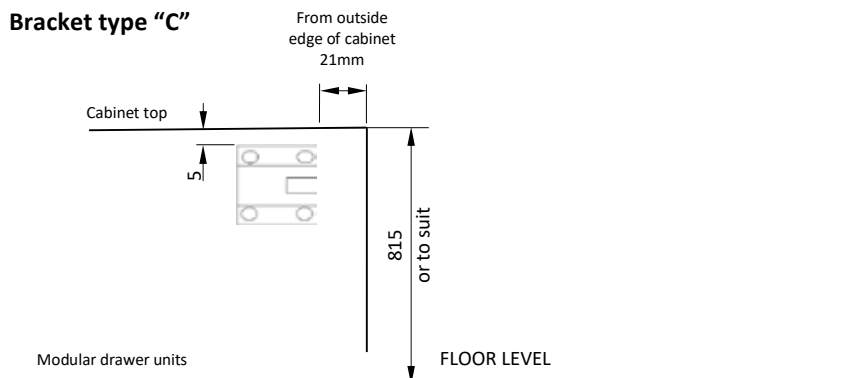

HANGING BRACKETS FOR BASE FURNITURE TYPE A

Note: Ensure that you use the correct fixing according to the type of wall construction. Use additional batons if needed.

Base units must each be anchored to the wall using the adjustable hanging brackets at the back of the unit. Draw a line on the wall with a spirit level where the nominal height of the top of the unit should be, this will make adjustment to the suitable level easy once the unit is hung. Mark out for the wall plate positions - **See Wall Hanger Matrix for the datum line detail**. Hang the unit onto the metal wall plate, making sure that the metal hook of the hanger locates properly on to the metal plate. The top screw give up and down adjustment and the bottom screw in and out adjustment.

1. Position the unit against the wall and over the wall plate.



2. Adjust the hanging bracket to the desired position.

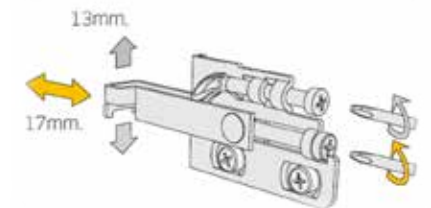

3. Lock the bracket in position by pushing the yellow locking mechanism toward the wall.



Adjoining units can be connected using the connecting bolts supplied. Drill through units once fastened to the wall and properly aligned. Use a wooden block on the inside of the adjoining unit to drill into.

Further information - https://youtu.be/wuF4_9AUm_U?si=B9IZiAKyiA63byDy

HANGING BRACKETS FOR BASE, WALL & TOWER FURNITURE TYPE B

Note: Ensure that you use the correct fixing according to the type of wall construction. Use addition batons if needed.



Base units must each be anchored to the wall using the adjustable hanging brackets at the back of the unit. Draw a line on the wall with a spirit level where the nominal height of the top of the unit should be, this will make adjustment to the suitable level easy once the unit is hung (**See Wall Hanger Matrix for the datum line detail**). Hang the unit onto the metal wall plate, making sure that the hanger locates properly on to the wall plate – **FIG A**.

Adjustment –

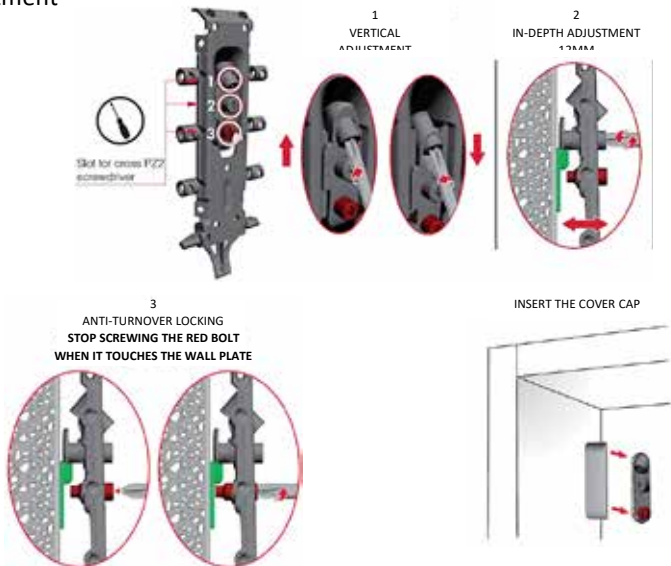

Adjoining units can be connected using the connecting bolts. Drill through units once fastened to the wall and properly aligned. Use a wooden block on the inside of the adjoining unit to drill into.

Further information - <https://youtu.be/6Bd5tsqxK10?si=HyxdXrD2pYB679Kq>

HANGING BRACKETS FOR BASE UNIT FURNITURE TYPE C

Note: Ensure that you use the correct fixing according to the type of wall construction. Use addition batons if needed.



Draw a line on the wall with a spirit level where the nominal height of the top of the unit should be, this will make adjustment to the suitable level easy once the unit is hung (**See Wall Hanger Matrix for the datum line detail**). Hang the unit onto the metal wall plate.

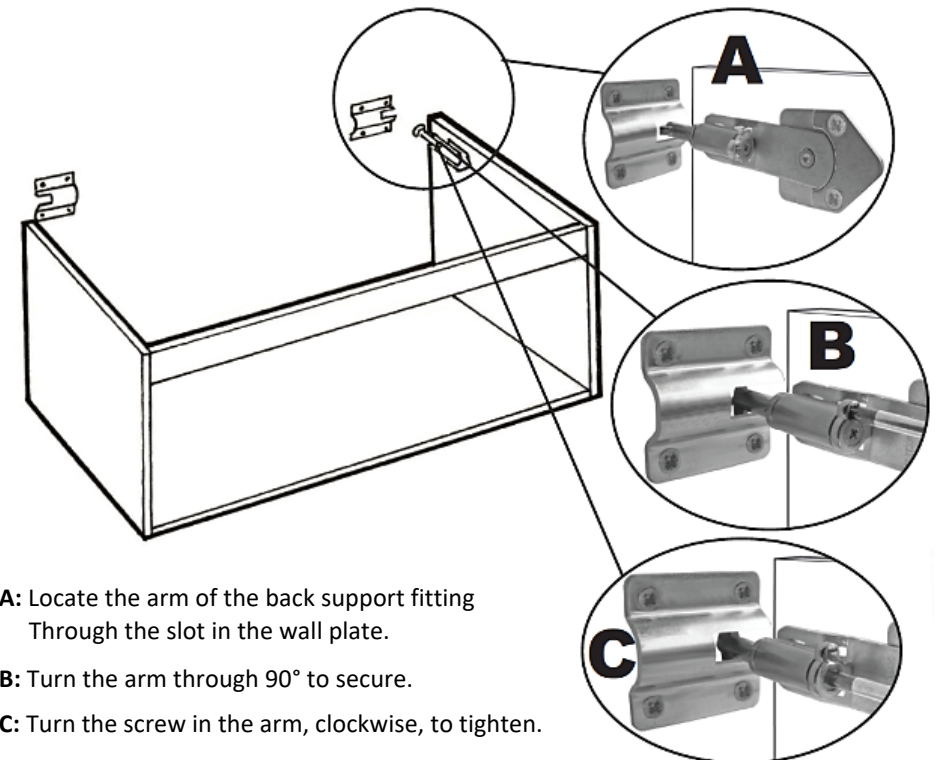

A: Locate the arm of the back support fitting through the slot in the wall plate.

B: Turn the arm through 90° to secure.

C: Turn the screw in the arm, clockwise, to tighten.

Fix lower support bracket to the wall
 Position the support brackets under the cabinet ends and mark the drill locations on the wall.
 Remove the cabinet and fix the brackets to the wall.
 Re-hang the cabinet.
 Lock & secure the top fittings.
 Adjust the lower support brackets as required.

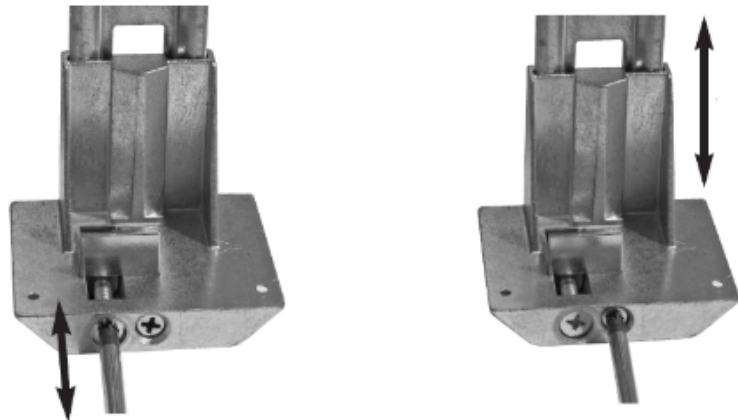
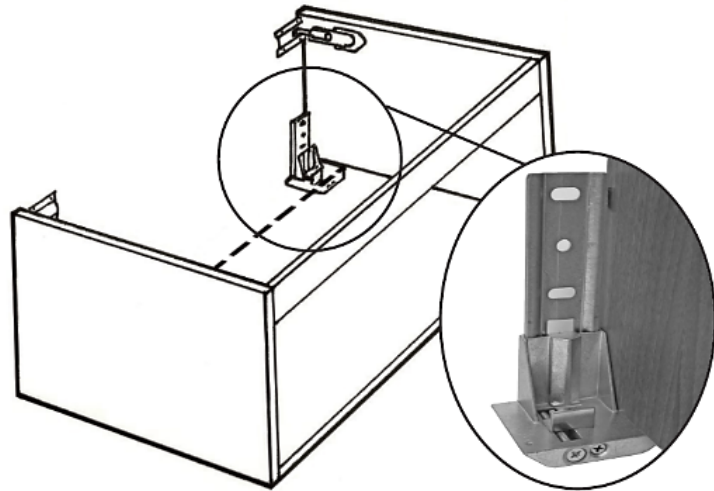

Further information - <https://youtu.be/YQ9Loi5GNHE?si=PGSiZOzR9itHdF5y>

ECO BATHROOM DOOR HINGE ADJUSTMENT

Up/Down:

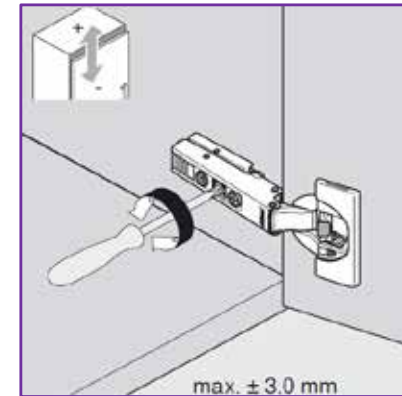

Left/Right:

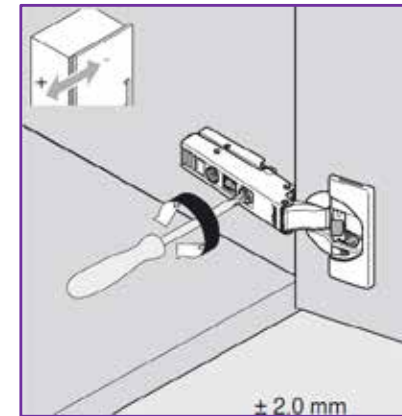

In/Out:

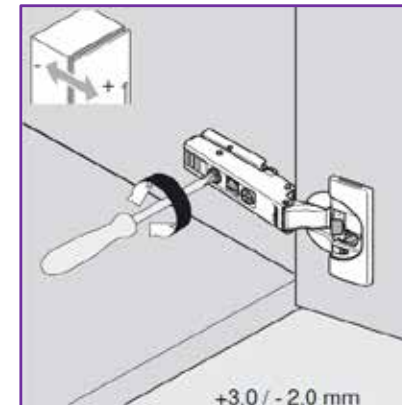

Further information - <https://youtu.be/0gpuAutmAf8?si=u7UjE15JbrnDqsPO>

Drawer Box Installation:

1. Ensure the cabinet has been fitted level and true.
2. Pull out the runners and place the drawer box onto the runners.
3. Close the drawer, ensuring that the drawer box is sitting flat onto the runners, until fully closed.

Drawer Box Removal:

Open fully and locate the polished metal levers, positioned underneath the drawer box. Push both levers' outwards, towards the side of the drawer unit. Lift the drawer box upward to release it from the runners.



LEVER

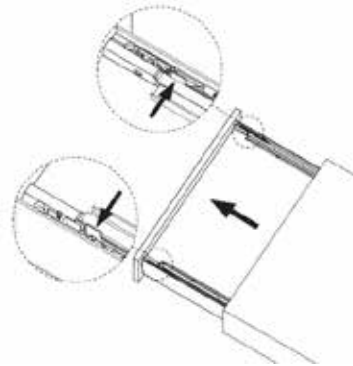

DRAWER ADJUSTMENT

Remove the cover cap and unlock screw X.

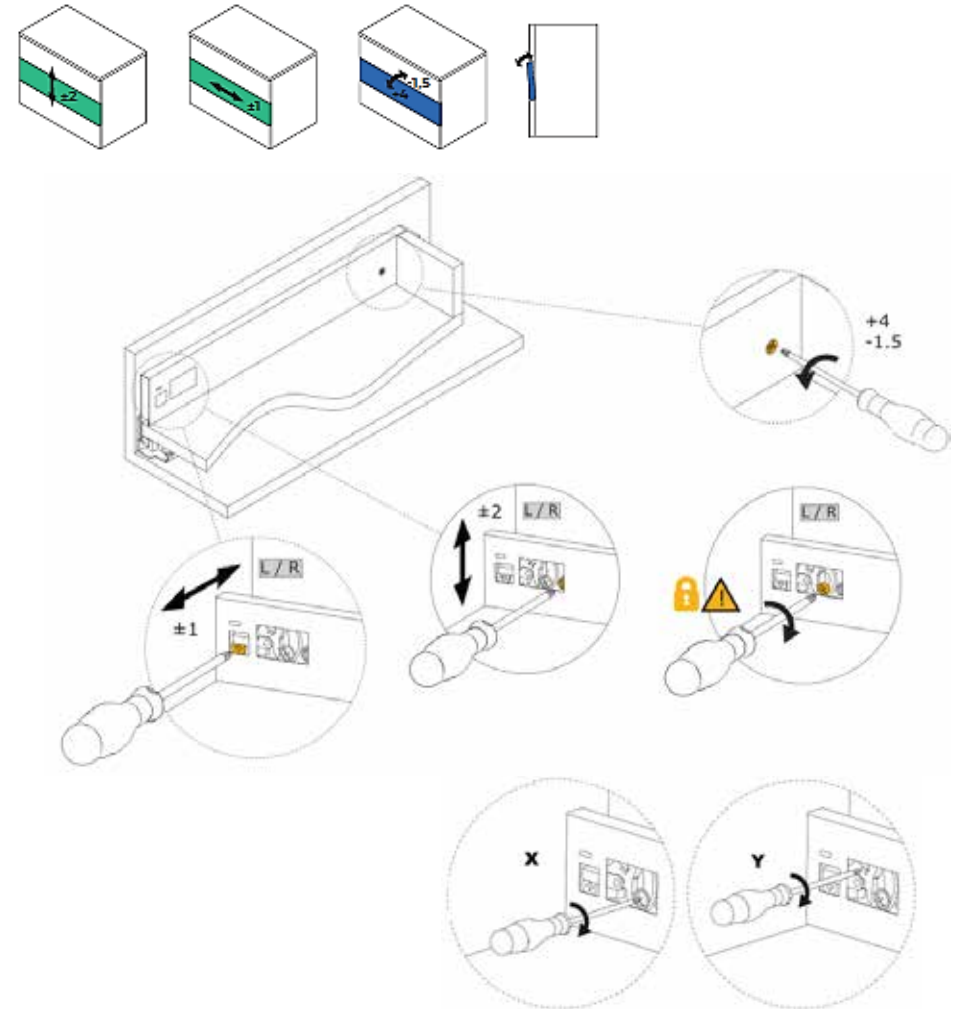

Drawer Front Removal:

Unlock screw X on both sides then insert screwdriver in Y and turn to release each side of the drawer front.

NOTE: For ease of access to "Y", adjust the drawer front height to the lowest position.

Further information - <https://youtu.be/pB05jwGKhz4?si=wDjbK8-pok64sP5y>

CHIARO MIRROR

NOTE- Installation to be carried out by a suitably qualified person.

Operation: Quick press of touch switch will power on or off. Long press will dim/brighten the LED surround light.

INSTALLATION INSTRUCTIONS

LED BATHROOM MIRROR LIGHT
Input: 230V~50Hz

- BSCHIAM50
- BSCHIAM60
- BSCHIAM70
- BSCHIAM90

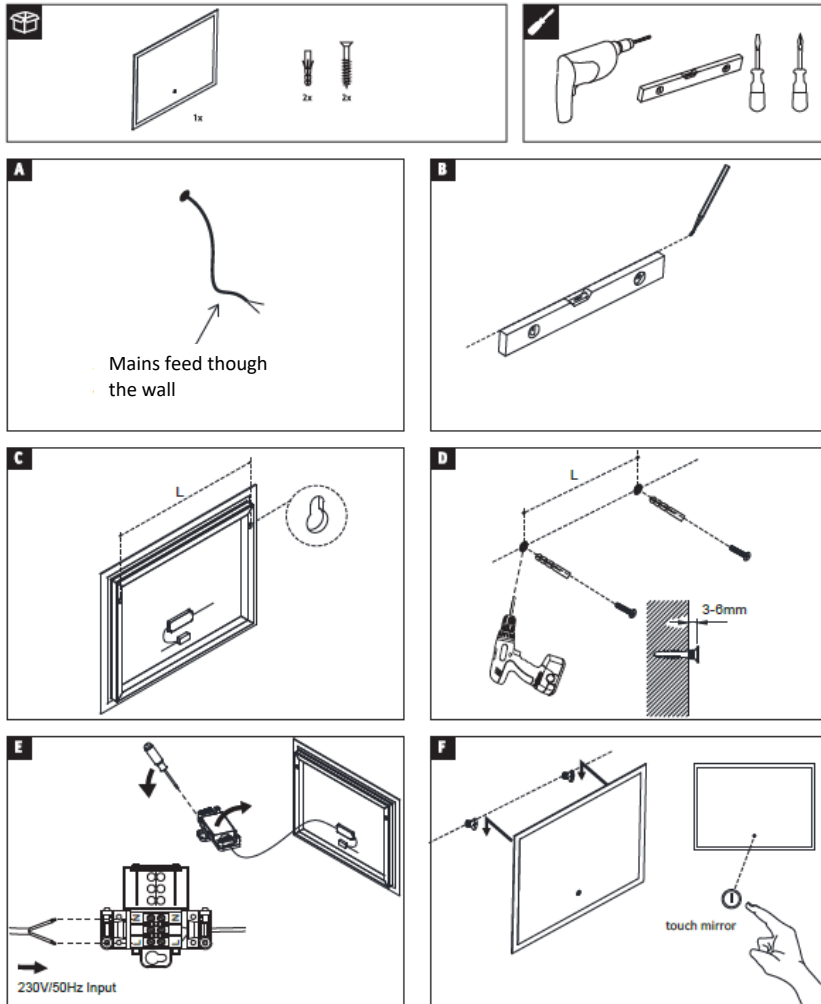

DRAWER ADJUSTMENT

Remove the cover cap and unlock screw X.

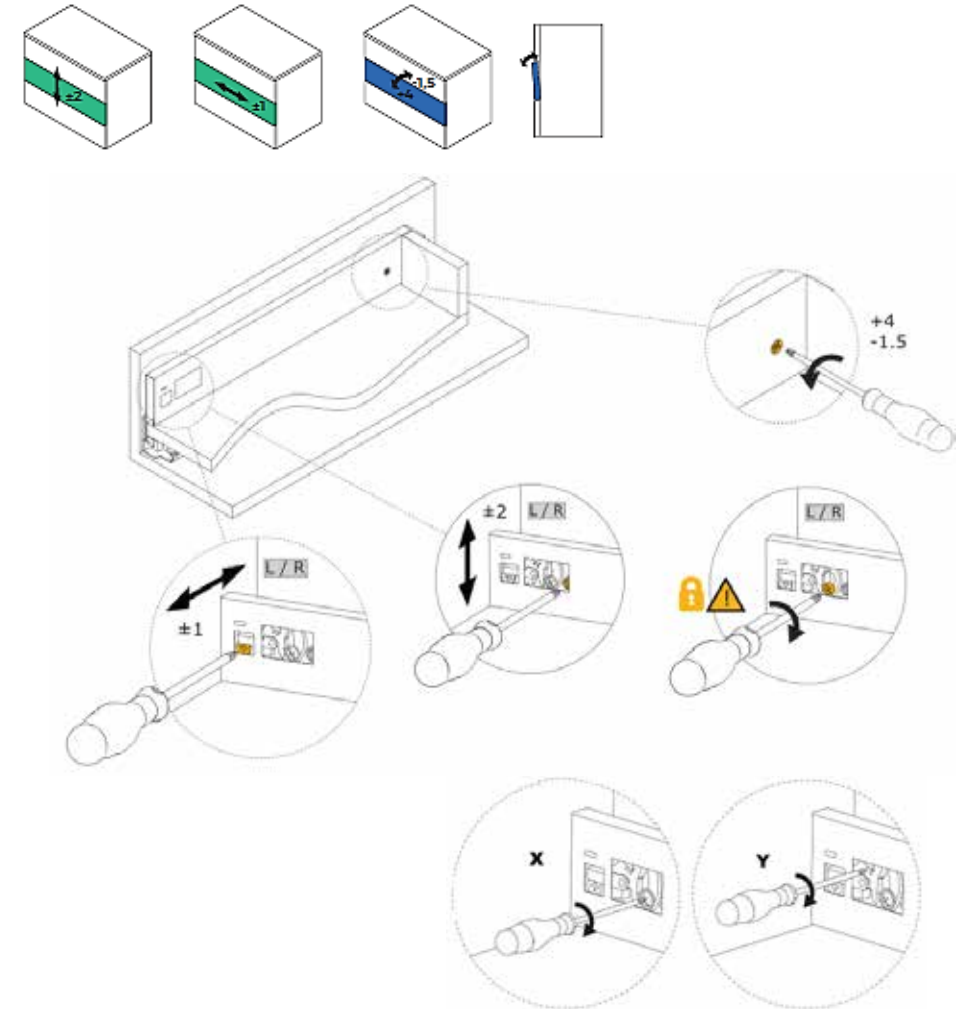

Drawer Front Removal:

Unlock screw X on both sides then insert screwdriver in Y and turn to release each side of the drawer front.

NOTE: For ease of access to “Y”, adjust the drawer front height to the lowest position.

Further information - <https://youtu.be/pB05jwGKhz4?si=wDjbK8-pok64sP5y>

ECO Bathrooms Solid Surface Worktop Installation

EcoStone is a composite of mineral, acrylic and resin that is ideal for bathroom installations. It is non-porous, durable and hygienic. Easy to cut and, as it is solid throughout, any cut face can be restored to the original finish.

Prior to Installation

Check the worktop for any sign of damage and scratches.
Look for obvious damage through the film. If matching more than one top, peel away the corners to check the colour match.

Note: any claim for damage after the worktop has been cut will not be accepted.

Ensure adequate support of the worktop whilst cutting.

Be aware of dust, and the environment you are in during cutting. Machine in a well-ventilated area and wear appropriate clothing/dust protection.

Good quality power tools with new sharp blades/hard tipped cutters can be used to cut EcoStone.

Installation

Always ensure adequate support during all stages of the cutting process.

Use masking tape for marking and to protect the surface during cutting.

Take time and care of accuracy for marking out prior to cutting.

Never force the cut, allow the tool to do the work.

Straight cut: Always cut into the front edge. Do not cut all the way through or chipping may occur as the tool exits the work surface. Machine about halfway and then cut in from the opposite direction.

Cut Out: Always cut into the front edge of the worktop and do not attempt a single cut or chipping may occur on the exit cut.

Tap Hole: Use a hole cutter and drill in from the top surface.

Finishing

Any cut surface can be restored to the original finish through a process of sanding. The process is typically as follows but may vary depending on the quality of the finished cut – Sand out the cut marks using a 240-grit paper (coarser may be required).

Sand out the marks from the previous stage using a 320-grit paper.

As above with a 500-grit finishing pad.

A cutting compound can be used to complete the process and then finish by applying a wax free polish.

Throughout the process keep cleaning away dust and debris from the surface. Do not go on a stage until the current stage is completed. Finally, install the finished worktop onto the units and secure using silicone.

Eco Bathroom Toilet Seats

Our toilet seats are made from environmentally friendly materials. The smooth, non-porous surface is ideal to maintain hygiene conditions.

Installation

Most Avalon Bathroom toilet seats are fixed using an Orizon Locking Plate. If this is not installed correctly the seat will work loose. Image A shows the Orizon Locking Plate located correctly. Image B shows the Orizon Locking plate upside down and image C shows the Orizon Locking Plate not located correctly. Always refer to the instructions supplied with the actual seat provided.



Care & Maintenance

Always install the seat and cover after completing the bathroom installation.

To ensure lasting satisfaction with the seat and cover you should observe the following.
Avoid exposure to direct sunlight.

Clean the seat, hinges and seat cover regularly with warm water and a mild detergent.
Afterwards rub dry.

Do not use abrasive cleaning products or products containing chloride or acids, as they may cause yellowing or peeling of the material. Neutral soap or mild, natural household cleaning products are the best for effective, problem free cleaning. After cleaning, wipe the seat with a well rung out cloth.

The seat, hinges and seat cover must not come into contact with WC cleaning agents.
Leave the seat and cover up whenever strong cleaning products are left in the bowl of the pan. Do not put them down again until the cleansing agent has been completely rinsed from the bowl, as the vapours from the cleanser may damage the surface of the toilet seat and fixings.

Tighten the hinges every six months or when needed to guarantee the correct operation.

Toilet Seat Best Practice & Common Issues

Seat movement:

If installed as instructed, there should be no excessive movement however, there will always be an element of movement due to the nature of the mechanical parts used.

Excessive weight and or movement of the occupier whilst sat will eventually cause the seat and fixings to work loose. As part of routine maintenance, the seat should be tightened up.

Common faults/causes of excessive seat movement:

- Fixings not located correctly.
- Fixings not tightened enough.
- Over tightening causing the thread to strip. Use only the tools supplied.

Staining or yellowing:

Can be caused by not following the recommended cleaning guidelines, hard water and UV sunlight.

No matter how careful men are, or how good your toilet hygiene is - yellowing of the toilet seat will happen over time.

Soft Closing:

The seat and cover must never be forced up or down. Slight resistance whilst lifting is normal and always allow to fall naturally. Seats and covers will fall at different rates. If neither land heavily nor is there excessive noise, then the soft closing mechanism is working as it should. Whilst toilet seats carry a 12 month guarantee the most common cause of soft close failure is due to the seat being forced. Longer term this will affect the soft close action permanently and invalidate the guarantee.

Cracked or split seats:

Broken toilet seats are not covered under the guarantee. Never stand on the seat or cover. Do not allow children to play with the seat or cover. General use and efficient operation take into consideration a maximum loading weight of 250lbs.

Toilet Seat Soft Close Adjustment (Bull, Quadra & Bull500)

The hinges for these seats are adjustable so, the speed at which the seat and/or lid fall, can be controlled. The left hinge controls the seat, and the right hinge controls the lid.

To adjust the rate of fall for the lid -

1. Remove the hinge from the right-hand side. Rotate toward yourself and re-insert. (Would suggest a quarter turn to start).
2. You will see that the hole to locate onto the fastening is now out of alignment. Insert a small bar and turn the hinge away from you until the hole is correctly aligned.
3. Place the seat back on to its fixing and try again.
Note: Time must be allowed for the mechanism to re-adjust internally.
4. If the lid still falls too fast, then adjust again.
5. If the seat now falls too slowly, remove the hinge, turn back slightly and replace, re-align the hole by turning toward you and reposition on the pan.

The above process applies to the left-hand side for the seat.

1. Place lid/seat on a flat surface.



4. Re-insert the hinge. Note the hole to locate onto the fixings is now out of alignment.



2. Slide out the hinge mechanism.



5. Insert a lever into the hole.
Slower – turn the lever away from you.
Faster – turn the lever toward you.



3. Slower - turn the hinge towards you.
Faster - turn the hinge away from you.



GENERAL NOTES

Any surface of the unit or laminate worktop which are cut during Installation must be re-sealed using an appropriate waterproof sealant. All basins must be sealed along all edges. Failure to re-seal cut surfaces or around a basin will invalidate the product warranty and may result in water damage.

Furniture Finishes: Furniture finishes may have some slight colour variation due to the different materials and manufacturing processes used.

Bath Panels: Must be installed under the lip of the bath. If a bath panel is cut, ensure the cut edge is sealed correctly. Once fitted the panel should be sealed around all edges. The method of fixing the panel is the responsibility of the installer. No fixings are supplied.

Plinths & Plinth Seals: Plinth seals are supplied with every plinth to protect against water ingress and must be fitted. If a plinth is cut, ensure the cut edge is sealed correctly.

Ceramic Sanitary ware: Due to the nature of materials and production processes dimensions of ceramic items may vary within a tolerance of $\pm 5\%$. The surfaces of ceramic products may contain minor imperfections. This is recognised within British Standards, due to the complex nature of producing ceramics.

Cast Marble Basins: Are designed and guaranteed to be used with hot water up to a maximum temperature of 65°C , this temperature must not be exceeded. Due to the nature of materials and production processes, dimensions of cast mineral basins may vary within a tolerance of $\pm 2\%$.

General Product Instruction: Various items such as toilet cisterns will be supplied with additional installation instructions. Ensure these are read fully and understood before installing them. Pass on to the end user along with this instruction.

All toilet seats have a soft closing action, allowing the seat/lid to land gently onto the pan with minimum force. This action varies from seat to seat. Never force the seat/lid or damage may occur.

Avalon Bathrooms reserve the right to amend or improve the product specifications at any time without notification. The company will not accept any liability regarding specification changes. All dimensions are approximate and are quoted within reasonable tolerances.

GUIDELINES FOR CARE AND MAINTENANCE

Our furniture is water resistant, not waterproof and is not designed for wet rooms. If excessive water spillages or heavy condensation is left on the product, the product will deteriorate, invalidating any guarantees. Every bathroom must be well ventilated and have a suitable extractor fan to avoid any persistent humidity. All spillages should be wiped up immediately.

Melamine, Vinyl and Foil Wrapped Doors:

Occasional marks, can in most cases, be removed with a soft damp cloth. More persistent marks can be removed using a non-silicone-based furniture cleaner. Hot soapy water should be avoided. Once the mark is removed, the area should be wiped over with a soft damp cloth to remove any excess and dried with a soft, clean cloth. On no account should solvent or an abrasive cleaner be used as permanent damage to the finish could take place.

High Gloss Doors:

Use cleaning products that do not contain abrasives, solvents, acid, or ammonia. Aggressive substances like acetone, alcohol, bleach could seriously damage the surface of the door. Our recommendation would be to use a soft cotton or micro fibre cloth with only water and mild detergent.

Note: Strong, direct sunlight can, on occasion, cause mellowing of the fascia colour over time. This is normal and does not affect the function of the product in any way.

Melamine Units & Components:

Do not use polish on any surface. A damp cloth with soapy water will clean off most marks or spills. Bleaches, scouring pads and multi-surface cleaners should not be used.

Soft close Drawers, & Hinges:

These should be wiped out with a damp soapy cloth and wiped dry with a soft cloth as necessary. The roller runners and hinges are lubricated and should not be cleaned with a degreasing agent as this will affect the action of the moving parts. Never lean on partially or fully opened doors and drawers to gain access to the units. The hinges are specified to adequately support the weight of the door, plus small additional weights such as wire accessories. It is advised that once the bathroom has been installed you should check every six months that all screws on the hinges are tight.

Laminate Worktops:

Although the worktop is hard wearing, sharp objects will scratch, and excessive heat will scorch the surface. Care should be taken not to drop any heavy objects onto the worktop as the surface may crack. For cleaning, a damp soapy cloth will clean off most spills. Bleaches, scouring pads and multi-surface cleaners should not be used. Corrosive liquids and make-up should be wiped off immediately. On no account should any spillage, even water, be allowed to lie on the surface. (Extra care should be taken with gloss worktops as these are more likely to scratch).

GUIDELINES FOR CARE AND MAINTENANCE

Solid Surface Worktops:

Composite work surfaces are easy to clean and maintain by following these simple care instructions. Avoid exposure to strong chemicals such as nail varnish remover, paint remover etc. These should be removed immediately. Always avoid sliding hard/sharp objects across the surface as this will result in scratches. Wiping the surface with a clean damp cloth and then buffing with a dry cloth will keep the surface in pristine condition.

Ceramic Sanitary Ware:

Clean with a damp cloth and warm soapy water. Rinse with clean water and polish with a soft cloth. Avoid using cleaners that contain abrasives, solvents, acid or ammonia.

Cast Marble Basins:

Clean with a damp cloth, water and soap or very mild detergent, rinse and polish with a soft cloth. Avoid using cleaners that contain abrasives, solvents, acid or ammonia. **Do not use caustic soda, rinse hair colouring agents or bleaches in these basins. Do not put cigarettes on these products.**

Mirrors:

Use a chamois leather, and dry with a suitable soft cloth. Any mirrors fitted with lights use a dry cloth to clean any electric components, ensure they are isolated before cleaning.

Glass Shelves:

Use a chamois leather, and dry with a suitable soft cloth. Warning - do not strike glass components with hard or pointed items as this may cause them to break.

Taps and Brassware:

Chrome and gold-plated finishes should be cleaned with warm water and a soft cloth rinsed and then dried. Finishes should be buffed with a dry cloth. Under no circumstances must any aggressive or abrasive cleaning agents be used.

Handles:

Chrome finishes should be cleaned with warm water and a soft cloth rinsed and then dried. Finishes should be buffed with a dry cloth. Under no circumstances must any aggressive or abrasive cleaning agents be used.

AVALON BATHROOMS GUARANTEE

The guarantee is limited to domestic use of the products by the consumer in a well-ventilated room fitted with an extractor fan.

All products must have been installed by experienced professional installers in accordance with our installation and care instructions, and to the appropriate regulations.

In the unlikely event that a product fails, within the guarantee period, we will offer a replacement or replacement parts (or nearest equivalent). Liability is limited to individual products and does not cover consequential loss, damages or any further installation costs involved. Products or components that are deemed defective because of incorrect or substandard fitting are not covered by the guarantee.

Should the installation be completed by a non-qualified person any product guarantee maybe considered invalid.

The guarantee is offered on all products used in the manner for which they were intended and does not apply to products that have been misused or abused in any way.

The guarantee does not include general wear and tear or damage.

Products replaced under guarantee are covered for the remainder of the original guarantee period only.

The guarantee is limited to the original purchaser and is not transferable. This guarantee does not affect your statutory rights.

Furniture: against manufacturing defects all furniture and fittings are covered by a five-year guarantee.

Laminate Worktops: against manufacturing defects all laminate worktops are covered by a five-year manufacturer's guarantee.

Solid Surface Worktops: against manufacturing defects all solid surface worktops are covered by a five-year manufacturer's guarantee.

Ceramic sanitary ware: against manufacturing defects covered by a one-year guarantee.

Cast marble basins: against manufacturing defects covered by a one-year manufacturer's guarantee.

Other Items:

Mirrors, handles, toilet seats, electrical fittings, and components together with illuminated mirrors are covered by a one-year manufacturer's guarantee.

Cisterns, taps, shower kits, including handsets, metal flexible tubes and pop-up wastes carry a one-year manufacturer's guarantee.

GUARANTEE REGISTRATION

Thank you for choosing to use Avalon Bathroom Furniture. The next stage is to register your product. Complete the guarantee registration (back page of this booklet) and return to:

Avalon Bathrooms
Guarantee Department
Avalon House
Bacup
Lancashire
OL13 0EA

Alternatively complete the form and email to guarantee@jjopl.com Please action within 14 days of installation, failing to do so may void any future warranty claims.

GUARANTEE CLAIMS

In the unlikely event that your product becomes faulty please contact your supplier direct for help and advice.

If you wish to make a claim under the guarantee please email us at the address above including a contact number, your post code, our order number (starts EB---), a brief description of the issue and at least four photographs showing the issue (we may ask for further images to ascertain the issue). Note without this information we cannot process your claim.

The Avalon Bathroom warranty does not cover damage caused by a 3rd party or the installer (for example leaks, excessive water ingress and damage).

The installation is not covered under the manufacturer guarantee and would be the responsibility of the installer or the provider of the installer.

The guarantee is offered on all products used in the manner for which they were intended and does not apply to products that have been misused or abused in any way.

NOTE REGARDING TOILET CISTERNS

If we have supplied a Thomas Dudley toilet cistern for your installation and should an issue arise with the cistern, we advise you contact their helpline direct. The customer service number is 0121 530 7000. They will require you to confirm where and when you purchased the product and the serial number. If you remove the top panel of the WC unit, the serial number can be found on the right-hand side of the cistern.



Thomas Dudley
Troubleshooting guide

Avalon

BATHROOMS

GUARANTEE REGISTRATION FORM

Name	Date Purchased	Date Fitted
<input type="text"/>	<input type="text"/>	<input type="text"/>
Bathroom furniture purchased from	Invoice Number	EB Number
<input type="text"/>	<input type="text"/>	<input type="text"/>
Main Contact Number	email address	
<input type="text"/>	<input type="text"/>	
Fitted or Modular furniture	Colour	
<input type="text"/>	<input type="text"/>	

This can be found on the packaging or contact your installer.

when complete return to:

Avalon Bathrooms
Guarantee Department
Avalon House
Bacup
Lancashire
OL13 0EA

Address

House No

Street Name

Town

Post Code

Please fill in and return to the address above or email to (guarantee@jjopl.com) within 14 days of installation, failing to do so may void any future warranty claims.

The installation of this product is not covered under the manufacturer guarantee and would be the responsibility of the installer or the provider of the installer.

Print version:

<https://www.jjopl.com/assets/support/Avalon-Guarantee-Form-022025.pdf>



